



PNOZ c2

► Safety relays

PILZ
THE SPIRIT OF SAFETY

This document is a translation of the original document.

All rights to this documentation are reserved by Pilz GmbH & Co. KG. Copies may be made for internal purposes. Suggestions and comments for improving this documentation will be gratefully received.

Source code from third-party manufacturers or open source software has been used for some components. The relevant licence information is available on the Internet on the Pilz homepage.

Pilz®, PIT®, PMI®, PNOZ®, Primo®, PSEN®, PSS®, PVIS®, SafetyBUS p®, SafetyEYE®, SafetyNET p®, the spirit of safety® are registered and protected trademarks of Pilz GmbH & Co. KG in some countries.



SD means Secure Digital

Introduction	4
Validity of documentation	4
Using the documentation	4
Definition of symbols	4
Safety	5
Intended use	5
Safety regulations	5
Safety assessment	5
Use of qualified personnel	5
Warranty and liability	6
Disposal	6
For your safety	6
Unit features	7
Safety features	7
Block diagram/terminal configuration	7
Function description	8
Installation	8
Wiring	8
Connect cable with crimp connector	9
Connect cable without crimp connector	10
Disconnect cable	10
Preparing for operation	11
Operation	12
Status indicators	12
Faults - malfunctions	13
Dimensions in mm	13
Technical details	14
Safety characteristic data	17
Supplementary data	17
Service life graph	18
Order reference	19
EC declaration of conformity	19

Introduction

Validity of documentation

This documentation is valid for the product PNOZ c2. It is valid until new documentation is published.

This operating manual explains the function and operation, describes the installation and provides guidelines on how to connect the product.

Using the documentation

This document is intended for instruction. Only install and commission the product if you have read and understood this document. The document should be retained for future reference.

Definition of symbols

Information that is particularly important is identified as follows:



DANGER!

This warning must be heeded! It warns of a hazardous situation that poses an immediate threat of serious injury and death and indicates preventive measures that can be taken.



WARNING!

This warning must be heeded! It warns of a hazardous situation that could lead to serious injury and death and indicates preventive measures that can be taken.



CAUTION!

This refers to a hazard that can lead to a less serious or minor injury plus material damage, and also provides information on preventive measures that can be taken.



NOTICE

This describes a situation in which the product or devices could be damaged and also provides information on preventive measures that can be taken. It also highlights areas within the text that are of particular importance.

**INFORMATION**

This gives advice on applications and provides information on special features.

Safety**Intended use**

The safety relay meets the requirements of EN 60947-5-1, EN 60204-1 and VDE 0113-1 and may be used in applications with dual-channel positive switching OSSDs such as

- ▶ periodically tested light guard type 2 in accordance with EN 61496-1
- ▶ Light guard type 4 EN 61496-1
- ▶ safe sensors with semiconductor outputs

The safety relay provides a safety-related interruption of a safety circuit.

The following is deemed improper use in particular:

- ▶ Any component, technical or electrical modification to the product
- ▶ Use of the product outside the areas described in this manual
- ▶ Use of the product outside the technical details (see Technical details).

**NOTICE****EMC-compliant electrical installation**

The product is designed for use in an industrial environment. The product may cause interference if installed in other environments. If installed in other environments, measures should be taken to comply with the applicable standards and directives for the respective installation site with regard to interference.

Safety regulations**Safety assessment**

Before using a unit it is necessary to perform a safety assessment in accordance with the Machinery Directive.

Functional safety is guaranteed for the product as a single component. However, this does not guarantee the functional safety of the overall plant/machine. In order to achieve the required safety level for the overall plant/machine, define the safety requirements for the plant/machine and then define how these must be implemented from a technical and organisational standpoint.

Use of qualified personnel

The products may only be assembled, installed, programmed, commissioned, operated, maintained and decommissioned by competent persons.

A competent person is a qualified and knowledgeable person who, because of their training, experience and current professional activity, has the specialist knowledge required. To be able to inspect, assess and operate devices, systems and machines, the person has to be informed of the state of the art and the applicable national, European and international laws, directives and standards.

It is the company's responsibility only to employ personnel who

- ▶ Are familiar with the basic regulations concerning health and safety / accident prevention,
- ▶ Have read and understood the information provided in this description under "Safety"
- ▶ Have a good knowledge of the generic and specialist standards applicable to the specific application.

Warranty and liability

All claims to warranty and liability will be rendered invalid if

- ▶ The product was used contrary to the purpose for which it is intended
- ▶ Damage can be attributed to not having followed the guidelines in the manual
- ▶ Operating personnel are not suitably qualified
- ▶ Any type of modification has been made (e.g. exchanging components on the PCB boards, soldering work etc.).

Disposal

- ▶ In safety-related applications, please comply with the mission time T_M in the safety-related characteristic data.
- ▶ When decommissioning, please comply with local regulations regarding the disposal of electronic devices (e.g. Electrical and Electronic Equipment Act).

For your safety

The unit meets all the necessary conditions for safe operation. However, please note the following:

- ▶ Note for overvoltage category III: If voltages higher than low voltage (>50 VAC or >120 VDC) are present on the unit, connected control elements and sensors must have a rated insulation voltage of at least 250 V.

Unit features

- ▶ Positive-guided relay outputs:
 - 2 safety contacts (N/O), instantaneous
- ▶ 1 semiconductor output (auxiliary output)
- ▶ Connection options for:
 - Type 2 or Type 4 light guards
 - safe sensors with semiconductor outputs (OSSD)
 - Start button
- ▶ LED display for:
 - Supply voltage
 - Switch status channel 1
 - Switch status channel 2

Safety features

The safety relay meets the following safety requirements:

- ▶ The circuit is redundant with built-in self-monitoring.
- ▶ The safety function remains effective in the case of a component failure.
- ▶ The correct opening and closing of the safety function relays is tested automatically in each on-off cycle.

Block diagram/terminal configuration

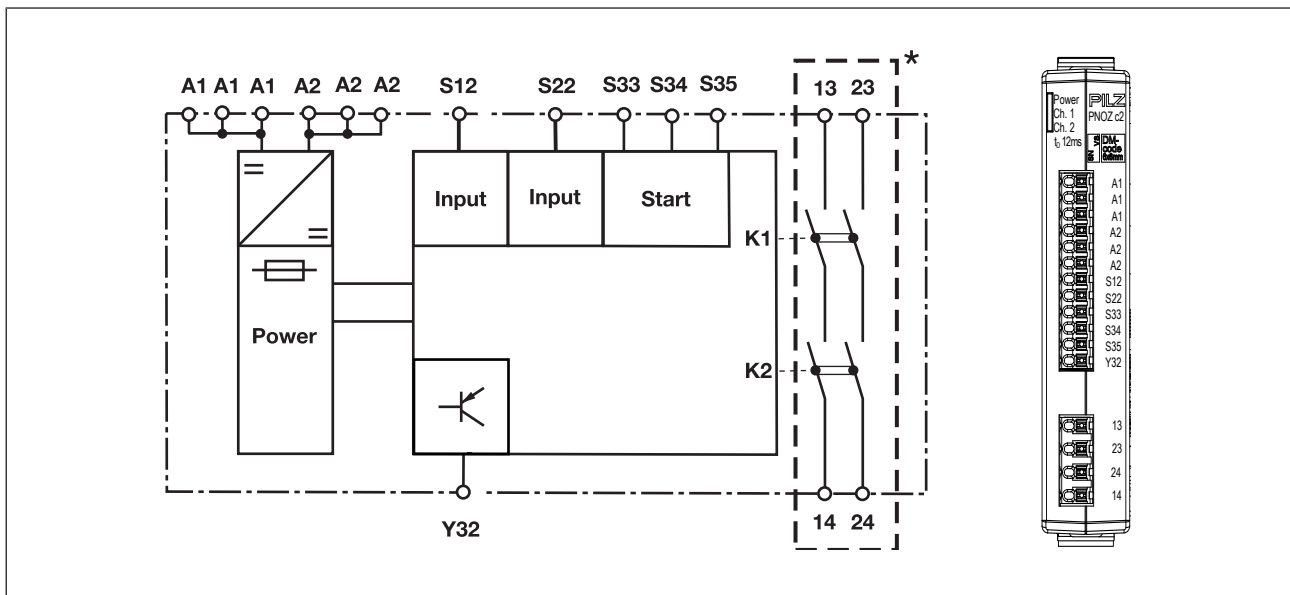

* Insulation from non-marked area: Safe separation (overvoltage category III),
 Insulation between relay contacts: basic insulation (overvoltage category III), safe separation (overvoltage category II)

Function description

When the supply voltage is supplied, the "POWER" LED illuminates. The unit is ready for operation when the start circuit is closed or a start contact in the start circuit is opened and then closed again.

- ▶ High signal at the input circuit (e.g. light guard not interrupted): The safety contacts are closed and the auxiliary contact is enabled.
- ▶ Low signal at the input circuit (e.g. light guard interrupted): The safety contacts are open and the auxiliary contact is disabled.
- ▶ Dual-channel operation without detection of shorts across contacts: Redundant input circuit, detects earth faults in the start and input circuit .
- ▶ Automatic start: Unit is active as soon as a high signal is present at the input circuit.
- ▶ Monitored start: Unit is active when there is a high signal at the input circuit is closed and then the start circuit is closed.
- ▶ Increase in the number of available contacts by connecting contact expander modules or external contactors/relays.

Installation

- ▶ The unit should be installed in a control cabinet with a protection type of at least IP54.
- ▶ Use the notch on the rear of the unit to attach it to a DIN rail.
- ▶ Ensure the unit is mounted securely on a vertical DIN rail (35 mm) by using a fixing element (e.g. retaining bracket or an end angle).

Wiring

Please note:

- ▶ Information given in the "Technical details" must be followed.
- ▶ Outputs 13-14 and 23-24 are safety contacts, the semiconductor output Y32 is an auxiliary output (e.g. for display).
- ▶ Semiconductor output Y32 should **not** be used for safety circuits!
- ▶ To prevent contact welding, a fuse should be connected before the output contacts (see Technical details).
- ▶ Use copper wire that can withstand 60/75 °C.
- ▶ Do **not** connect capacitive load.
- ▶ Do not switch low currents using contacts that have been used previously with high currents.
- ▶ The power supply must comply with the regulations for extra low voltages with protective electrical separation (SELV, PELV) in accordance with VDE 0100, Part 410.
- ▶ Ensure the wiring and EMC requirements of IEC 60204-1 are met.

**INFORMATION**

The voltage at the inputs S12, S22 has to be at least 24 V DC less the lower tolerance value of the supply voltage (s. technical details). When the voltage is too low, increase the supply voltage until at least the lower tolerance value is reached at the inputs.

Connect cable with crimp connector

- ▶ Strip the cable [1] and apply a crimp connector.
- ▶ Insert the stripped cable with the crimp connector applied into the terminal point [2] [3] as far as it will go.

**NOTICE**

Do not use a tool to connect the cable.

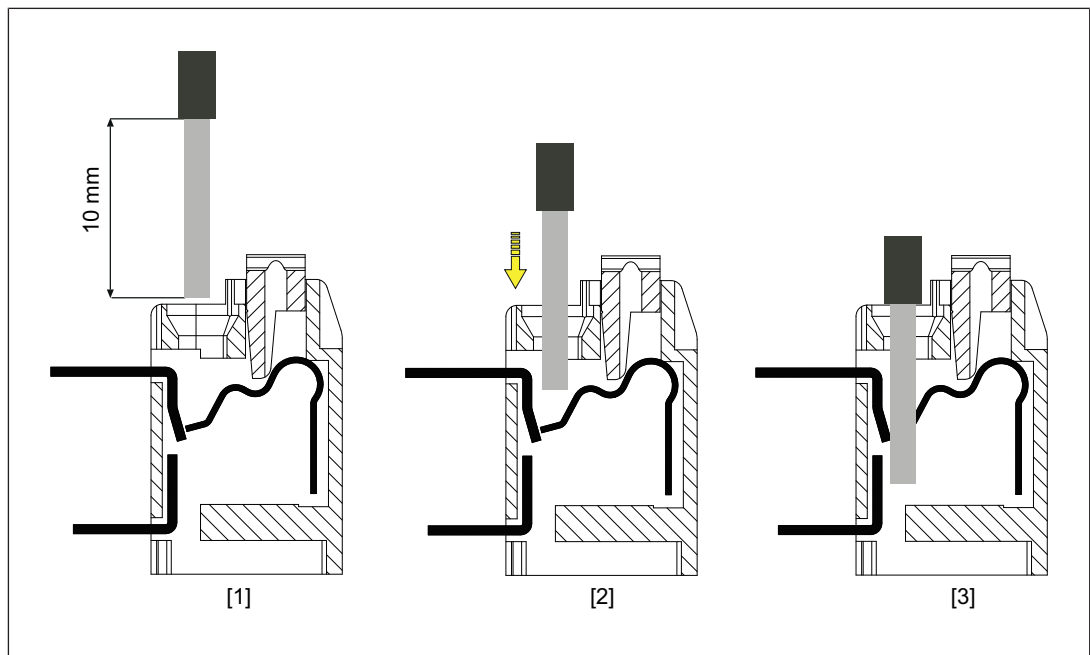

Fig.: Connect cable with crimp connector

Connect cable without crimp connector

- ▶ Strip the cable [1].
- ▶ Using the screwdriver, press the actuator button [2] and insert the stripped cable into the terminal point [2] [3] as far as it will go.

We recommend you use a screw driver with a 0.4 x 2.5 mm (DIN 5264) blade!

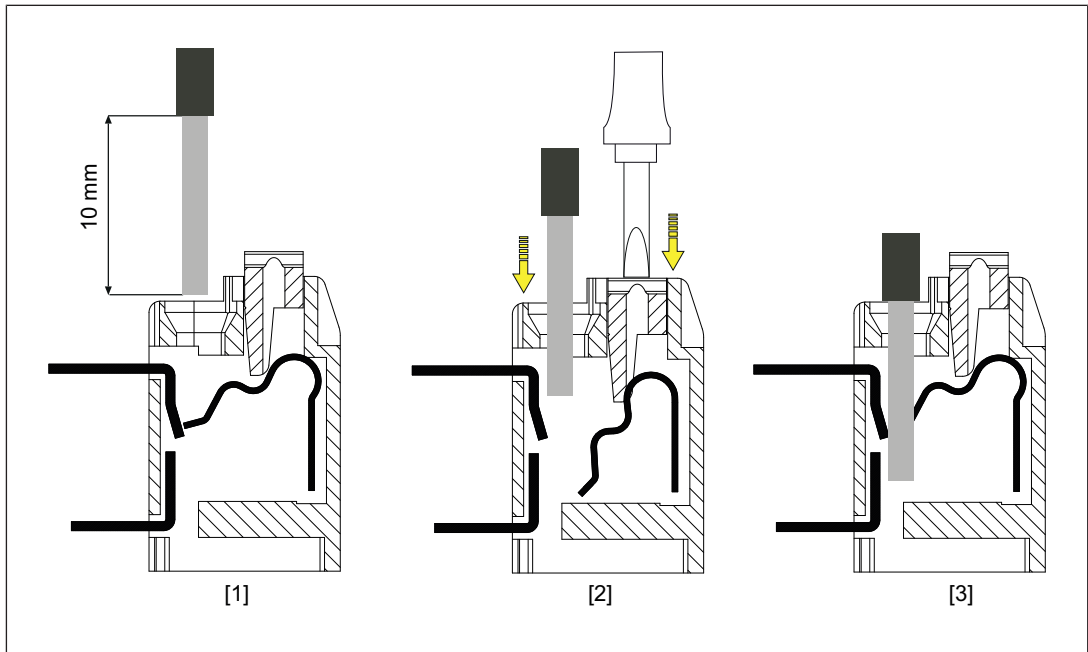

Fig.: Connect cable without crimp connector

Disconnect cable

We recommend you use a screw driver with a 0.4 x 2.5 mm (DIN 5264) blade!

- ▶ Using the screwdriver, press the actuator button and pull the cable out of the terminal point [4].

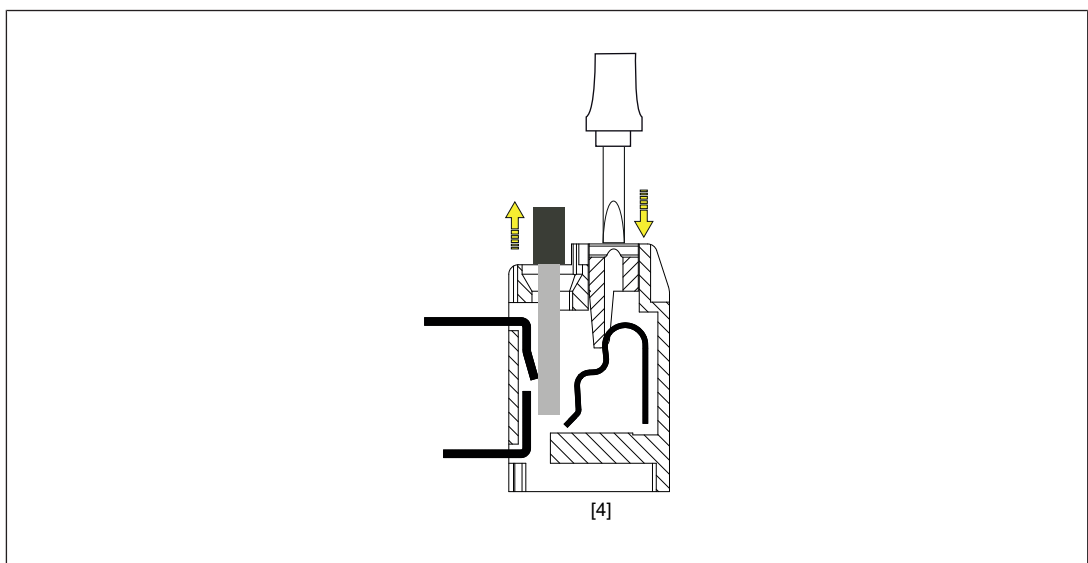

Fig.: Disconnect cable

Preparing for operation

Supply voltage	AC	DC
Input circuit	Single-channel	Dual-channel
Light grid of safe sensor with detection of shorts across contacts and short-circuit-proof OSSDs		



NOTICE

It must **not** be possible to switch off the supply voltage for the PNOZ c2 separately from the supply voltage for the safe sensor or the light guard.

* When operated with a light guard: Use the free connections A1 and A2 to connect the supply voltage for the transmitter.

Start circuit/feedback loop	Start circuit	Feedback loop
automatic start		
Monitored start		

**NOTICE****In the event of an automatic start:**

The unit starts up automatically when the safeguard is reset, e.g. when the E-STOP pushbutton is released. Use external circuit measures to prevent an unexpected restart.

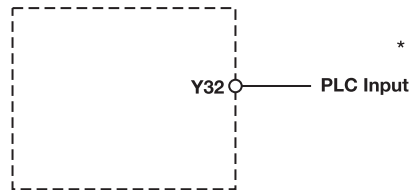
Semiconductor output

*Connect together the 0V connections on all the external power supplies

Operation

In switched-on state of relay outputs the mechanical contact of the relay cannot be tested automatically. Depending on the operational environment, measures to detect the non-opening of electromechanical contact elements may be required under some circumstances.

When using the product in accordance with the European Machinery Directive it has to be checked whether the safety contacts of the relay outputs open correctly. Start the device again or open the safety contacts (switch off output), so that the internal diagnostics can check the correct opening of the safety contacts

- ▶ for SIL CL 3/PL e at least 1x per month
- ▶ for SIL CL 2/PL d at least 1x per year

**NOTICE**

The safety function should be checked after initial commissioning and each time the plant/machine is changed. The safety functions may only be checked by qualified personnel.

The unit is ready for operation when the Power LED is permanently lit.

LEDs indicate the status and errors during operation:

Status indicators**POWER**

Supply voltage is present.

**CH.1**

Safety contacts of channel 1 are closed.

**CH.2**

Safety contacts of channel 2 are closed.

Faults - malfunctions

- ▶ Contact malfunctions: If the contacts have welded, reactivation will not be possible after the input circuit has opened.

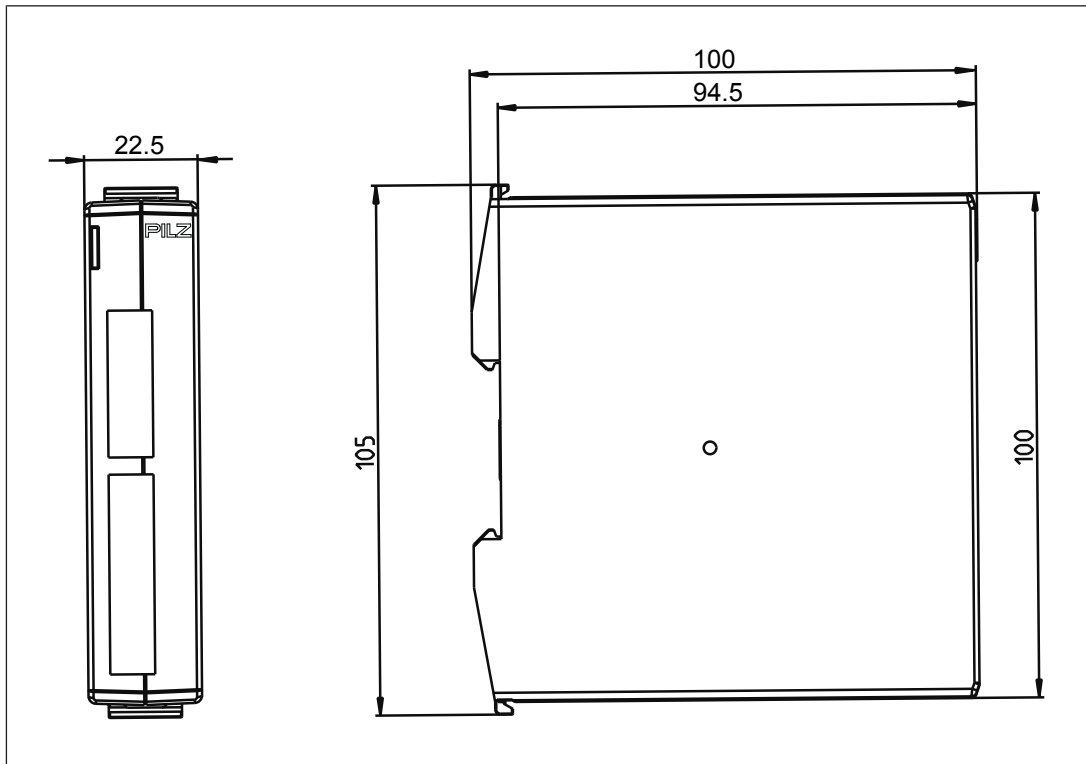
Dimensions in mm

Technical details

General	
Approvals	CCC, CE, EAC (Eurasian), TÜV, cULus Listed
Electrical data	
Supply voltage	
Voltage	24 V
Kind	DC
Voltage tolerance	-20 %/+20 %
Output of external power supply (DC)	3 W
Residual ripple DC	20 %
Duty cycle	100 %
Max. inrush current impulse	
Current pulse, A1	2 A
Pulse duration, A1	4 ms
Inputs	
Number	2
Voltage at	
Input circuit DC	24 V
Start circuit DC	24 V
Feedback loop DC	24 V
Current at	
Input circuit DC	30 mA
Start circuit DC	40 mA
Feedback loop DC	40 mA
Max. inrush current impulse	
Current pulse, input circuit	0,2 A
Pulse duration, input circuit	70 ms
Current pulse, feedback loop	0,15 A
Pulse duration, feedback loop	1 ms
Current pulse, start circuit	0,15 A
Pulse duration, start circuit	1 ms
Semiconductor outputs	
Number	1
Voltage	24 V
Current	20 mA
Relay outputs	
Number of output contacts	
Safety contacts (N/O), instantaneous	2
Max. short circuit current IK	1 kA
Utilisation category	
In accordance with the standard	EN 60947-4-1

Relay outputs

Utilisation category of safety contacts

AC1 at	240 V
Min. current	0,01 A
Max. current	3 A
Max. power	750 VA
DC1 at	24 V
Min. current	0,01 A
Max. current	4 A
Max. power	100 W

Utilisation category

In accordance with the standard	EN 60947-5-1
---------------------------------	---------------------

Utilisation category of safety contacts

AC15 at	230 V
Max. current	1,5 A
DC13 (6 cycles/min) at	24 V
Max. current	1,5 A

Utilisation category in accordance with UL

Voltage	240 V AC G.U. (same polarity)
With current	3 A
Voltage	24 V DC G. U.
With current	4 A
Pilot Duty	B300, R300

External contact fuse protection, safety contacts

In accordance with the standard	EN 60947-5-1
Max. melting integral	66 A²s
Blow-out fuse, quick	4 A
Blow-out fuse, slow	3,15 A
Blow-out fuse, gG	4 A
Circuit breaker 24V AC/DC, characteristic B/C	3 A

Conventional thermal current

4 A

Contact material

AgCuNi + 0,2 µm Au**Times**

Switch-on delay

With automatic start typ.	200 ms
With automatic start max.	550 ms
With monitored start with rising edge typ.	20 ms
With monitored start with rising edge max.	50 ms

Delay-on de-energisation

With E-STOP typ.	5 ms
With E-STOP max.	12 ms

Recovery time at max. switching frequency 1/s

After E-STOP	300 ms
--------------	---------------

Waiting period with a monitored start

With rising edge	300 ms
------------------	---------------

Times	
Min. start pulse duration with a monitored start	
With rising edge	30 ms
Supply interruption before de-energisation	20 ms
Simultaneity, channel 1 and 2 max.	∞
Environmental data	
Climatic suitability	EN 60068-2-78
Ambient temperature	
Temperature range	-10 - 55 °C
Storage temperature	
Temperature range	-40 - 85 °C
Climatic suitability	
Humidity	93 % r. h. at 40 °C
Condensation during operation	Not permitted
EMC	EN 60947-5-1, EN 61000-6-2, EN 61000-6-4, EN 61326-3-1
Vibration	
In accordance with the standard	EN 60068-2-6
Frequency	10 - 55 Hz
Amplitude	0,35 mm
Airgap creepage	
In accordance with the standard	EN 60947-1
Overvoltage category	III
Pollution degree	2
Rated insulation voltage	250 V
Rated impulse withstand voltage	6 kV
Protection type	
Mounting area (e.g. control cabinet)	IP54
Housing	IP40
Terminals	IP20
Mechanical data	
Mounting position	Any
Mechanical life	10,000,000 cycles
Material	
Bottom	PC
Top	PC
Connection type	Spring-loaded terminal
Mounting type	Fixed
Conductor cross section with spring-loaded terminals	
1 core flexible without crimp connector	0,25 - 1,5 mm², 24 - 16 AWG
1 core flexible with crimp connector	0,25 - 0,75 mm², 24 - 20 AWG
Spring-loaded terminals: Terminal points per connection	1
Stripping length with spring-loaded terminals	10 mm

Mechanical data

Dimensions

Height	105 mm
Width	22,5 mm
Depth	100 mm

Weight	160 g
--------	--------------

Where standards are undated, the 2016-11 latest editions shall apply.

Safety characteristic data**NOTICE**

You must comply with the safety-related characteristic data in order to achieve the required safety level for your plant/machine.

Operating Mode	EN ISO 13849-1: 2015	EN ISO 13849-1: 2015	EN 62061 SIL CL	EN 62061 PFH _D [1/h]	IEC 61511 SIL	IEC 61511 PFD	EN ISO 13849-1: 2015 T _M [year]
	PL	Category					
Safety contacts, instantaneous	PL e	Cat. 4	SIL CL 3	2,31E-09	SIL 3	2,03E-06	20

Safety contacts, instantaneous

All the units used within a safety function must be considered when calculating the safety characteristic data.

**INFORMATION**

A safety function's SIL/PL values are **not** identical to the SIL/PL values of the units that are used and may be different. We recommend that you use the PAscal software tool to calculate the safety function's SIL/PL values.

Supplementary data**CAUTION!**

It is essential to consider the relay's service life graphs. The relay outputs' safety-related characteristic data is only valid if the values in the service life graphs are met.

The PFH value depends on the switching frequency and the load on the relay output. If the service life graphs are not accessible, the stated PFH value can be used irrespective of the switching frequency and the load, as the PFH value already considers the relay's B10d value as well as the failure rates of the other components.

Service life graph

The service life graphs indicate the number of cycles from which failures due to wear must be expected. The wear is mainly caused by the electrical load; the mechanical load is negligible.

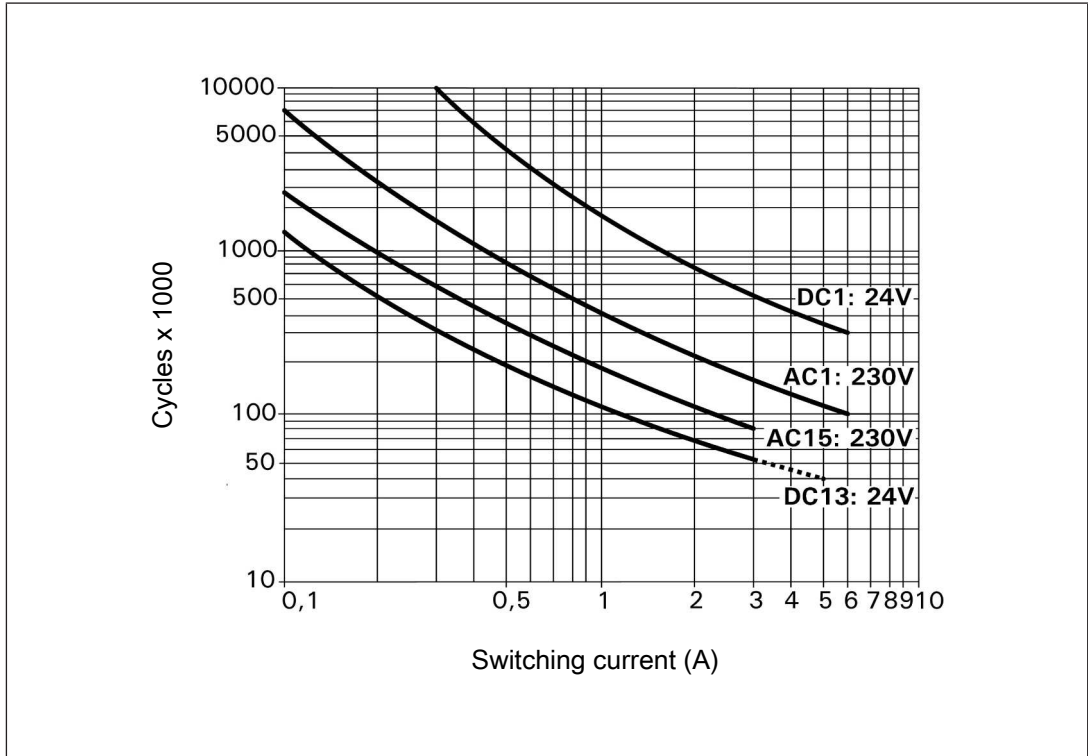

Fig.: Service life graphs at 24 V DC and 230 V AC

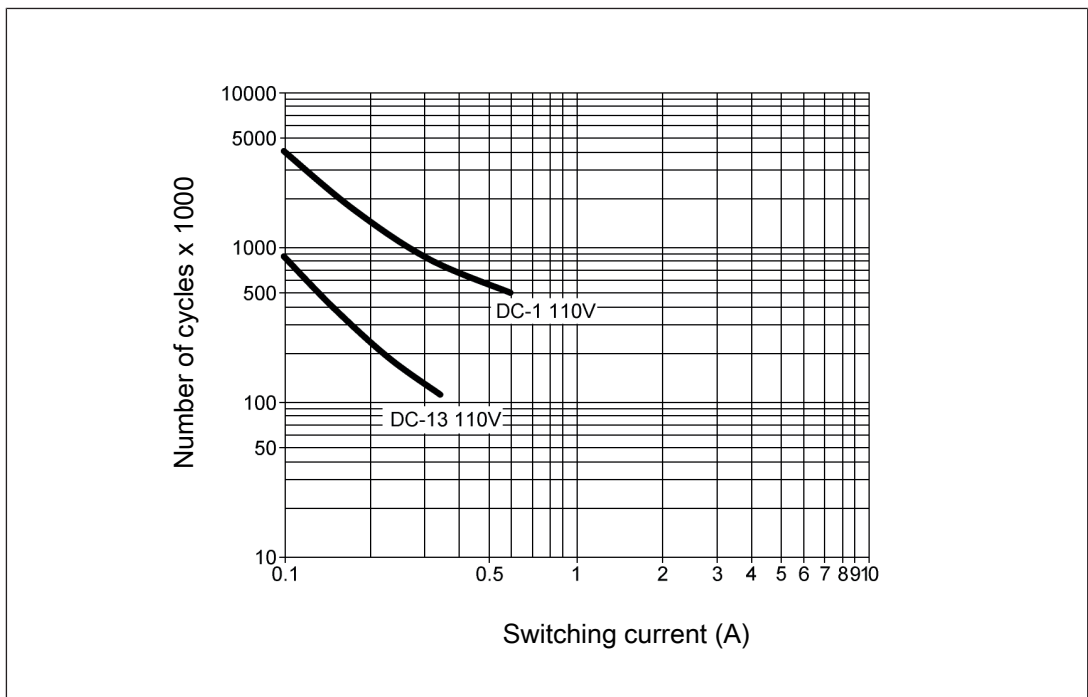

Fig.: Service life graphs at 110 V DC

Example

- ▶ Inductive load: 0.2 A,
- ▶ Utilisation category: AC15
- ▶ Contact service life: 1 000 000 cycles

Provided the application to be implemented requires fewer than 1 000 000 cycles, the PFH value (see Technical details) can be used in the calculation.

To increase the service life, sufficient spark suppression must be provided on all output contacts. With DC contactors, use flywheel diodes for spark suppression.

Order reference

Product type	Features	Terminals	Order No.
PNOZ c2	24 VDC	With spring-loaded terminals	710 002

EC declaration of conformity

This product/these products meet the requirements of the directive 2006/42/EC for machinery of the European Parliament and of the Council. The complete EC Declaration of Conformity is available on the Internet at www.pilz.com/downloads.

Representative: Norbert Fröhlich, Pilz GmbH & Co. KG, Felix-Wankel-Str. 2, 73760 Ostfildern, Germany